

CANFLEX[®]
(Formerly Known as CANNON)

“ Design and Manufactures of...
Flexible Pouch Packaging Machines ”

Canflex offers a complete range of Packaging Machines for Powders,
Granules, Liquids, Viscous & Non-Viscous & all FMCG Products.

10 MW
MULTI HEAD WEIGH FILLER



CANFLEX ENGINEERING PVT. LTD.

P.B. No. 1919, D. No. 7-2-C8/A & C33/A, Industrial Estate,
Sanathnagar, Hyderabad - 500018, T.S., INDIA.

Tel: +(91)-40 23712233, 23716699, 98486-22825
Fax: +(91)-40 23813884

Email: info@cannonindia.com

Website: www.cannonindia.com
www.canflexindia.com

Application: Free Flow uneven Crispy products Like Potato Chips, Flakes, Namkeen's, Corn,

Description: Mechanically operated fully automatic form fill & seal machine to pack Free Flow uneven Crispy products Like Potato Chips, Flakes, Namkeen's, Dry foods Chocolates & Candies with multi head electronic load cell based weigh metric combination weigh filler. (14 stations) fabricated with heavy duty angular structure weigher supported on channel platform, all contacts parts made out with SS, Machine is controlled by HMI touch screen panel with Photo cell Inclusive.

01. Feeding System	: 10 head Multi head combination weigher	13. Pouch Length	: Up to 300mm
02. Production Speed	: 25-40 Pouches per min (Depends on Range)	14. Pneumatic air	: 15cfm@7 kg/cm ² (5hp. air compressor)
03. Machine control system	: P.L.C (Programmed Logic Controller) touch screen	15. Power Consumption	: 1 kW / Hour
04. Packing range	: 50,100, 200, 500 grams & 1Kg	16. Peak Power	: 6 kW
05. Film Width	: Up to 450mm	17. Power requirement	: 3 Phase, 415 V, 50Hz plus Neutral
06. Film Thickness	: 70 - 100 microns	18. Film Guard mechanism	: Auto stop when film is exhausted
07. Film Material	: Any heat sealable Laminated	19. Pouch Counter	: Provided
08. Sealer heating system	: Continues	20. Date printing Device	: Optional
09. Inner Core Dia. of Film Roll	: 70mm	21. Photo Cell	: Provided
10. Outer Dia. of the film Roll	: Up to 350mm	22. Machine Dimensions in "mm"	: 1500(H) x 1100(W) x 1300(Depth)
11. Pouch Style	: Center seal pillow pouches	23. Net Weight	: 600kgs (approx)
12. Pouch Width	: Up to 210mm		

Note: Due to R&D and products enhancements technical data are subject to change without prior notice.

Technical Diagram

Front View

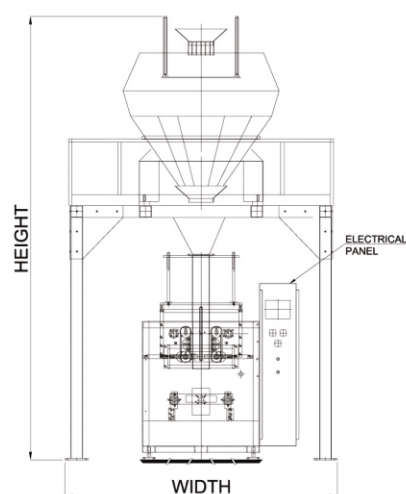

Side View

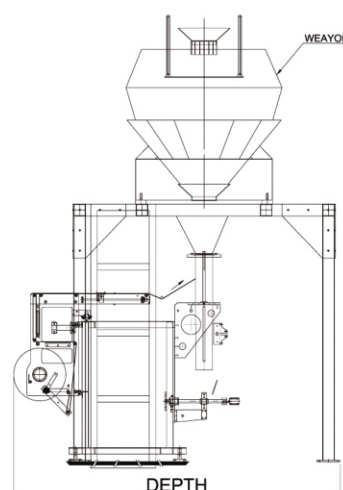

CANFLEX ENGINEERING PVT. LTD.

P.B. No. 1919, D. No. 7-2-C8/A & C33/A, Industrial Estate,
Sanathnagar, Hyderabad - 500018, T.S., INDIA.

Tel: +(91)-40 23712233, 23716699, 98486-22825
Fax: +(91)-40 23813884

Email: info@cannonindia.com
Website: www.cannonindia.com
www.canflexindia.com